

immersion depth ET = 50
shorter length optional

M14x1,5
SW17
female nut optional

1100°C...600°C
600°C...250°C
250°C...130°C
130°C

Tip Temp.	Output
-40 °C	357 mV
0 °C	472 mV
50 °C	628 mV
100 °C	792 mV
250 °C	1.322 mV
500 °C	2.329 mV
750 °C	3.400 mV
1.000 °C	4.475 mV
1.100 °C	4.896 mV

harness connection:
red or brown +12...+24V
white or blue SIG 0,3..5,0V
black GND

min. bending radius of cable:
5 x cable diameter
No bending of shrink tube

Options marked in red
Ausführungsvarianten rot markiert

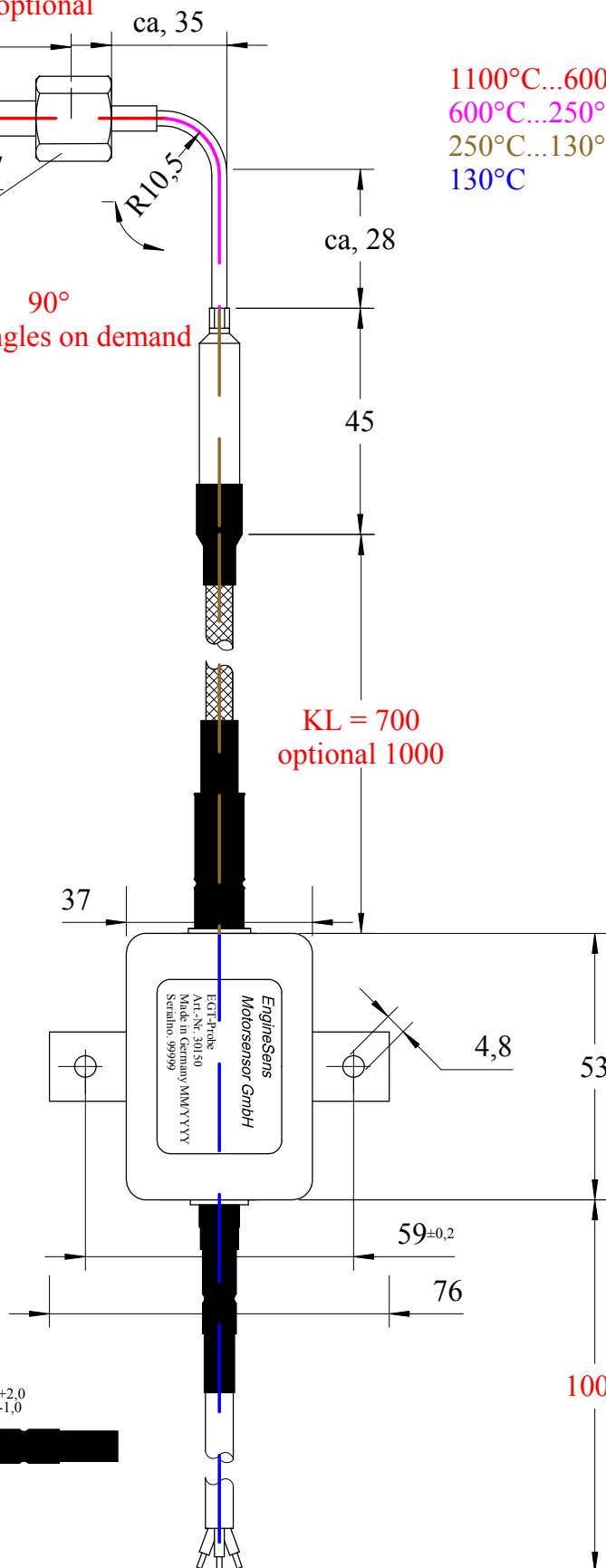
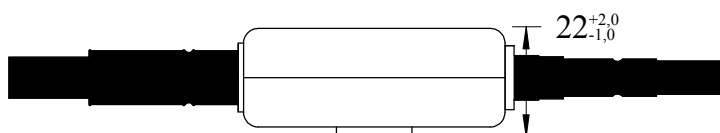

Allgemeintoleranzen gem. ISO 2768				Datum	Name	Exhaust gas temperature probe DTS-V III Version EngineSens Motorsensor part-no. 30150
				Bearb. 22.12.2010	S. Carstens	
				Gepr.		
d	options red marked	26.03.2014	sc	Norm		
c	new color scheme	24.11.2013	sc	TurboCAD16.1	Maßstab ca. 1:1,5	
b	new PCB:DTS-VII=>II	16.01.2012	sc			
a	fixing device	27.10.2011	sc			
Index	Änderung	Datum	Name	EngineSens Motorsensor GmbH Mannheimer Str. 44b phone +49 (0)6204-986 08 23 D-68519 Viernheim fax +49 (0)6204-986 08 25		